

GLASS WASHING

FRONT DOOR STYLE GLASS WASHER

MODEL: _____ PROJECT: _____ ITEM #: _____ QTY: _____

PRODUCT IMAGE



GWD-24 SHOWN

STANDARD FEATURES

- Low Temperature
- Stainless Steel construction
- **Free 1 Year Warranty** if Glass Washing Dump Sink is purchased and placed next to Glasswasher in Bar Line-Up
- 26" Front to Back depth, 38 3/4" when door is open
- 11" glass clearance accepts taller stemware
- Dual NSF listed as both a glasswasher and a dishwasher
- Counter balanced door
- Reduced water usage
- Low water tank heat protection
- Built-in detergent, rinse-aid, and sanitizing pumps
- Wash pump, 1 HP motor
- Fresh water rinse
- Thermostatically controlled wash tank heater maintains water at the required temperature
- Single Phase 115 V connection, 12 Amps
- Fully automatic wash/rinse cycle processes a rack of wares in 1 1/2" minutes, 30 racks an hour (600 glasses an hour total)

OPTIONAL ACCESSORIES

- **28-111S** 3 1/2" x 3 1/2" Plate Caster with 5" Locking Wheel



APPROVED BY:

CERTIFICATIONS:

Due to our commitment to continued product improvement, specifications are subject to change without notice.

GLASS WASHING

FRONT DOOR STYLE GLASS WASHER

MODEL: _____ PROJECT: _____ ITEM #: _____ QTY: _____

LOW TEMPERATURE FRONT DOOR STYLE GLASS WASHER

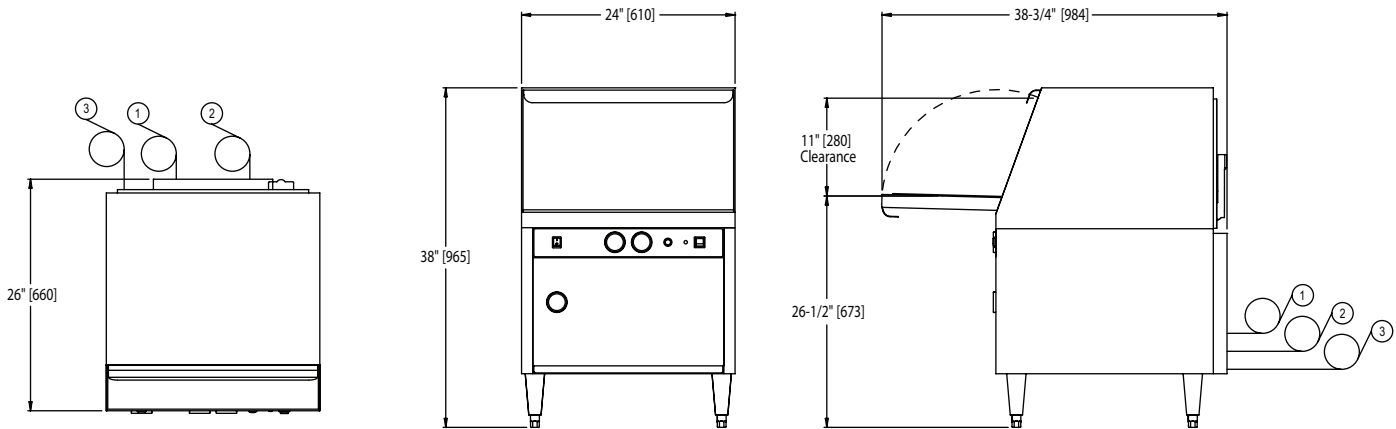

PLAN VIEW

FRONT VIEW

SIDE VIEW

SPECIFICATIONS

CAPACITY

Cycle time (seconds)	90
Racks per hr. (NSF)	30

MOTOR HORSEPOWER

Wash	1
------	---

WATER CONSUMPTION

U.S. Gallons per hr. (Max use)	49.2
U.S. Gallons per rack	1.64

TEMPERATURES °F/C

Wash/Rinse	140
------------	-----

HEATING

Tank heat, electric (kW)	.75
--------------------------	-----

TIME CYCLE in SECONDS

Wash	45
Rinse	17
Drain/Fill	28
Total Cycle	90

STANDARD 20" x 20" RACK COMPLIMENT

Dish/Open	1
-----------	---

UTILITIES

Ⓐ ELECTRICAL

115/60/1; 2 wire plus ground, 12 Amps.

Ⓑ WATER

1/2" Supply; 140°F Min. hot water connection, 6 ft. long, 1/2" I.D. flexible fill hose with 3/4" hose connector. Flow pressure 25-95 PSI

Ⓒ DRAIN CONNECTION

5/8" I.D. flexible reinforced hose, 6 ft. long. Max drain flow 15 US gpm, Max drain height 3 ft.

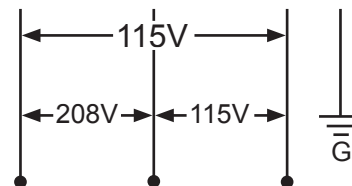

UNIT DIMENSIONS

	HEIGHT	WIDTH	DEPTH	SHIP WT. (lbs.)
UNCRATED	38"	25"	25"	178
CRATED	46 1/2"	27"	27 1/2"	198



APPROVED BY:

Due to our commitment to continued product improvement, specifications are subject to change without notice.