

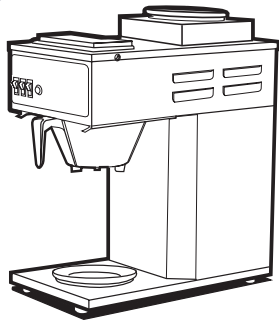

# Service Manual - Cafe Pourover



## MODELS INCLUDED

- CAFE 1DB
- CAFE 2DB
- CAFE 3DB
- CAFE AP
- CAFE 0PP



**CAUTION:** Please use this setup procedure before attempting to use this brewer. Failure to follow the instructions can result in injury or the voiding of the warranty.



**CAUTION:** Allow brewcone to drain before removing.



ISO 9001:2008 REGISTERED

WILBUR CURTIS CO., INC.  
 6913 West Acco Street  
 Montebello, CA 90640-5403  
 For the latest information go to  
[www.wilburcurtis.com](http://www.wilburcurtis.com)  
 Tel: 800-421-6150  
 Fax: 323-837-2410

## SETUP STEPS



**CAUTION -** This brewer is shipped with the thermostat turned ON. DO NOT plug in unit before pouring 3 pots or 192 oz. of water into the opening (see step 4, below); damage to the heating element or thermostat will result.

1. Place the brewer on a solid, level counter top, near a 120 VAC outlet rated at 20 amps.
2. Place an empty glass decanter on the warmer deck, under the sprayhead.
3. Insert an empty brewcone into the brew rails unit (fig. 1.).
4. Slowly fill the tank with room temperature water through the opening on the top cover until water starts running in a steady stream from the brewcone (3 pots or 192 ounces). The tank is full.
5. Plug power cord into a 120V electrical outlet.
6. Allow the brewer to heat up to full temperature, indicated by the green Ready to Brew light. This takes about 15 to 25 minutes the first time the coffee brewer is plugged in. Slight dripping from the brewcone is normal as the tank heats up.

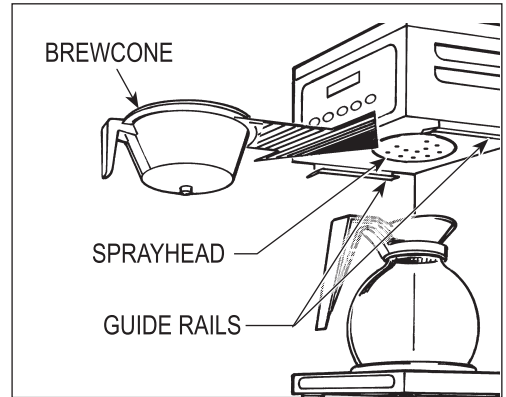

Figure 1. Sprayhead and brewcone

## BREWING INSTRUCTIONS

1. Pour ground coffee evenly into the filter and place it into the brew cone.
2. Slide brew cone into guide rails (fig. 1.). Place a clean empty decanter on the warmer plate (model Café AP will use an airpot).
3. When the green Ready to Brew light comes on, add 64 ounces or one decanter of room temperature water into opening on the top cover (fig. 3.). Brewing will take about three minutes.
4. Switch on the warmer plates to keep the coffee at serving temperature.



Figure 2. Pour ground coffee into filter.



**NOTE:** Due to evaporation, water may be lost from the tank if brewer is left on for long periods of time without making coffee. When this occurs, pour in enough water to refill the heating tank before brewing.



**NOTE:** You should have at least two decanters for brewing coffee. One for pouring water, the other to brew coffee into. Airpot brewers will require a pitcher that holds 74 ounces (see figure 3).

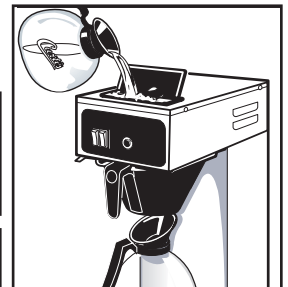
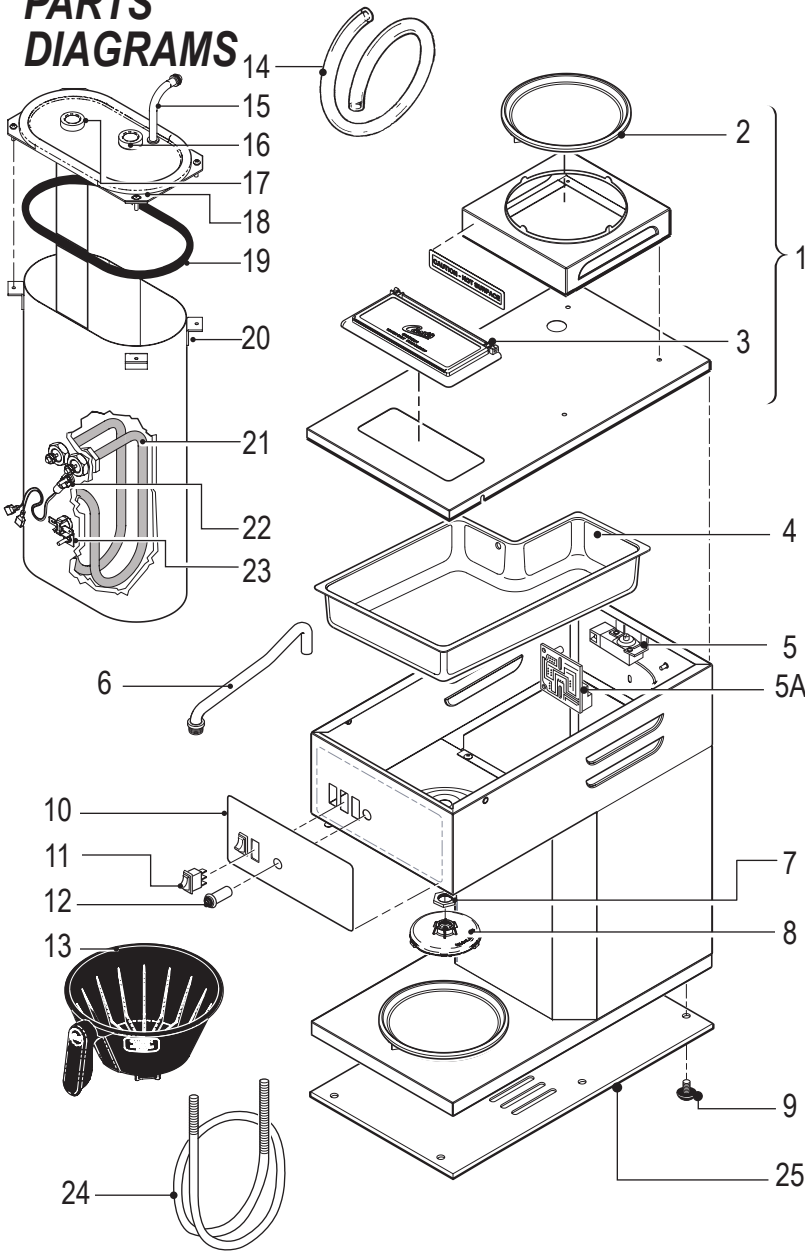

Figure 3. Pour cold water into pour hole.

This appliance is designed for commercial use. Any servicing other than cleaning and maintenance should be performed by an authorized Wilbur Curtis Company service center.

- Do not immerse the unit in water or any other liquid
- To reduce the risk of fire or electric shock, do not open top panel. No user serviceable parts inside. Repair should be done only by authorized service personnel.
- Keep hands and other items away from hot parts of unit during operation.
- Never clean with scouring powders or harsh implements.

# PARTS DIAGRAMS



Item N°	Part N°	Description
1	WC-68101	TOP WARMER ASSY, 120V (CAFÉ 2DB)
1A	WC-68103	TOP WARMER ASSY, 220V (CAFÉ 2DB)
2	WC-37135	WARMER ASSY 100W 120V w/PLATE
2B	WC- 975	WARMER ASSY, COMPLETE 100W 220V
3**	WC-54118	TRAY ASSY POUROVER
4**	WC-54121	PAN, POUR CAFÉ'
5	WC- 504	THERMOSTAT CAPILLARY (EXPORT MODELS)
5A**	WC- 735-101	THERMOSTAT, TEMP CONTROL 120V
6**	WC-29054	TUBE, CAFÉ SPRAYHEAD/SYPHON
7	WC-4213	NUT, 5/8-18 JAM BRASS
8**	WC-29025	SPRAYHEAD, PURPLE ASF
9	WC-3502	LEG, SCREW BUMPER
10	WC-39372	LABEL, SW PANEL CAFÉ 1DB (ON/OFF SW)
10A	WC-39373	LABEL, SW PANEL CAFÉ 2DB (ON/OFF SW)
10B	WC-39374	LABEL, SW PANEL CAFÉ 3DB (ON/OFF SW)
10C	WC-39371	LABEL, SW PANEL CAFÉ AP (ON/OFF SW)
11**	WC- 165	SWITCH, WARMER RED 115V
11A	WC- 166	SWITCH, WARMER (RED) 250V
11B	WC- 137*	SWITCH, WARMER RED 220V (OLDER UNITS)
12	WC- 207	LIGHT, BREW 115V GREEN
12A	WC- 208	LIGHT, BREW 250V GREEN
13	WC-3621-101	BREWCONE, 7/8" BLK PLASTIC
14**	WC-5310	TUBE, 5/16 ID X 1/8 W SILICONE
15	WC-29042	HOSE, VENTILATION HEATING TANK
16	WC-2627	GROMMET, COVER HEATING TANK
17	WC-2628	BUSHING, CONICAL.47 ID x .95 OD x .99L 8mm
18	WC-54125-101	COVER, TOP HEATING TANK
18A	WC-54125*	COVER, TOP HEATING TANK (OLDER UNITS)
19**	WC-43062	GASKET, TANK LID
20	WC-54117	TANK, COMPLETE 1450W 120V
20A	WC-54145	TANK, COMPLETE 3500W 240V
21**	WC- 917-04	ELEMNT, HEAT1.45KW 120V W/NUTS & WSHRS
21A	WC- 906-04	ELEMENT, HEATING 2KW 220V W/NUT & WSHR
22**	WC-1438-101	SENSOR, TEMPERATURE TANK
23**	WC- 523*	THERMOSTAT, MANUAL RESET
23A	WC- 521	THERMOSTAT, , AUTO RESET
24	WC-3645	SPRING, DELIMING CAFÉ SERIES
25	WC-73106	COVER, BOTTOM
26	WC-68102	COVER ASSY, TOP (CAFÉ 1DB, 3DB, AP)

\* Component Used on Older Units

\*\* Suggested Parts to Stock

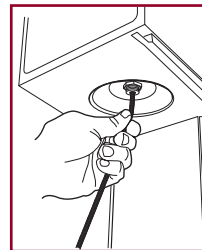
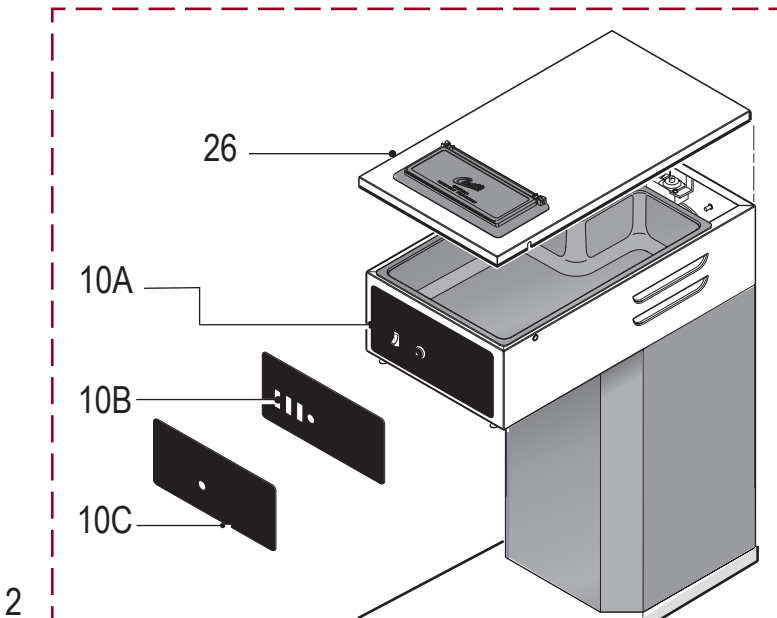

**DELIMING SPRING** This spring is for cleaning lime deposits from within the siphon tube. Remove the sprayhead. Insert spring into the siphon tube. Twist the spring clockwise as you push inward. Once past the bend in the tubing, you can slide it back and forth to remove hard lime deposits.



**NOTE:** Items, called out in this illustration, are specific to Cafe 1DB, Cafe 3DB & Café AP. All other parts are common.

## THERMOSTAT ADJUSTMENT

The Cafe coffee brewer is factory set to 200°F. The brewer can be adjusted on the thermostat for a tank temperature of either 200°F or 190°F.

To adjust:

1. Unplug the unit at the power cord.
2. Remove the back cover, held by four screws.
3. Locate the thermostat, attached to a bracket below the top wrap. There will be a pair of contacts covered with a black plug (see photo, right, 200°F). This is where the tank temperature selection is made. Removing the black plug changes the setting to 190°F. Covering the contacts will return the setting to 200°F. To avoid losing the small black cover, slip the cover over one of the contacts as shown in photo at right.
4. Return cover to the back of the unit and plug electrical cord into the power outlet.

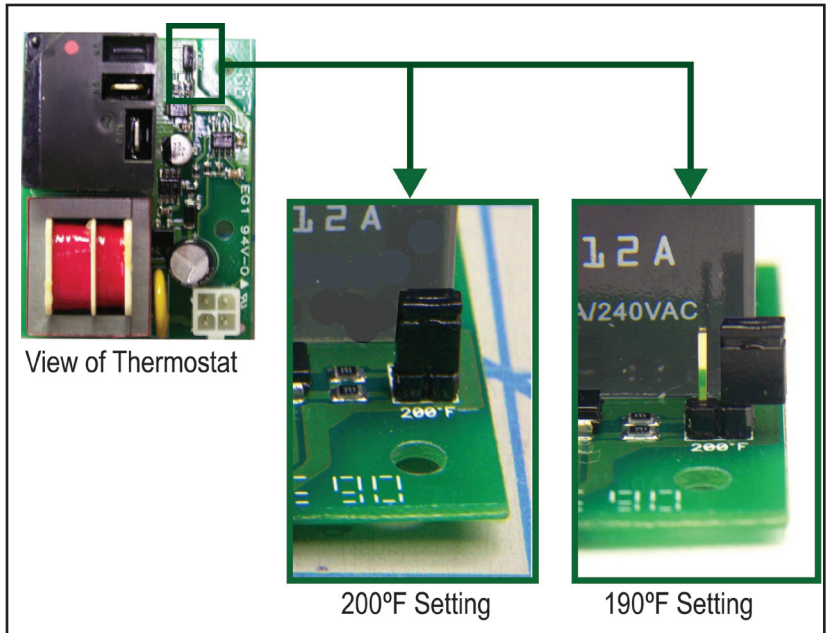

## CLEANING

Regular cleaning of your Curtis Cafe coffee brewer will maintain the highest quality coffee your equipment is capable of producing. Proper cleaning is essential in maintaining the fresh and appealing appearance of your coffee service.

1. First turn off the brewer, unplugging the cord at the power outlet.
2. Avoid touching hot surfaces. Allow the warmer plates to cool.



**CAUTION** - Do not use cleansers, liquid bleach, powders or any other substance that contains chlorine. These products promote corrosion and will pit the stainless steel. **THE USE OF THESE PRODUCTS WILL VOID YOUR WARRANTY.**

3. Wipe all exterior surfaces with a damp cloth. Remove spills, dried coffee, coffee grounds, etc.
4. Slide the brewcone out and wipe the sprayhead area with a cloth dampened with a mild dish soap solution.
5. Wash the brewcone and wire brew basket, if applicable. Use a soft bristled brush for hard to clean areas. Wash both parts with a detergent solution or put these parts through a dishwasher.
6. Wash glass decanters with dish soap. To remove mineral deposits, soak with vinegar.
7. Dry all exterior surfaces of the unit with a clean soft cloth to keep water from spotting the cabinet.

NOTE - Polish the outside stainless steel surfaces with stainless steel polish after drying. This will prevent surface scratches and result in a cleaner appearance.

## DE-LIMING

Every six months, more often in areas with extremely hard water, the inside of the heating tank should be de-limed.



**CAUTION** - The de-liming procedure must be performed by a qualified service technician.

# ELECTRICAL LADDER DIAGRAM – 120V

Brewer Model Café 1DB, 2DB, 2DBS, 3DB & AP (All 120VAC Units)

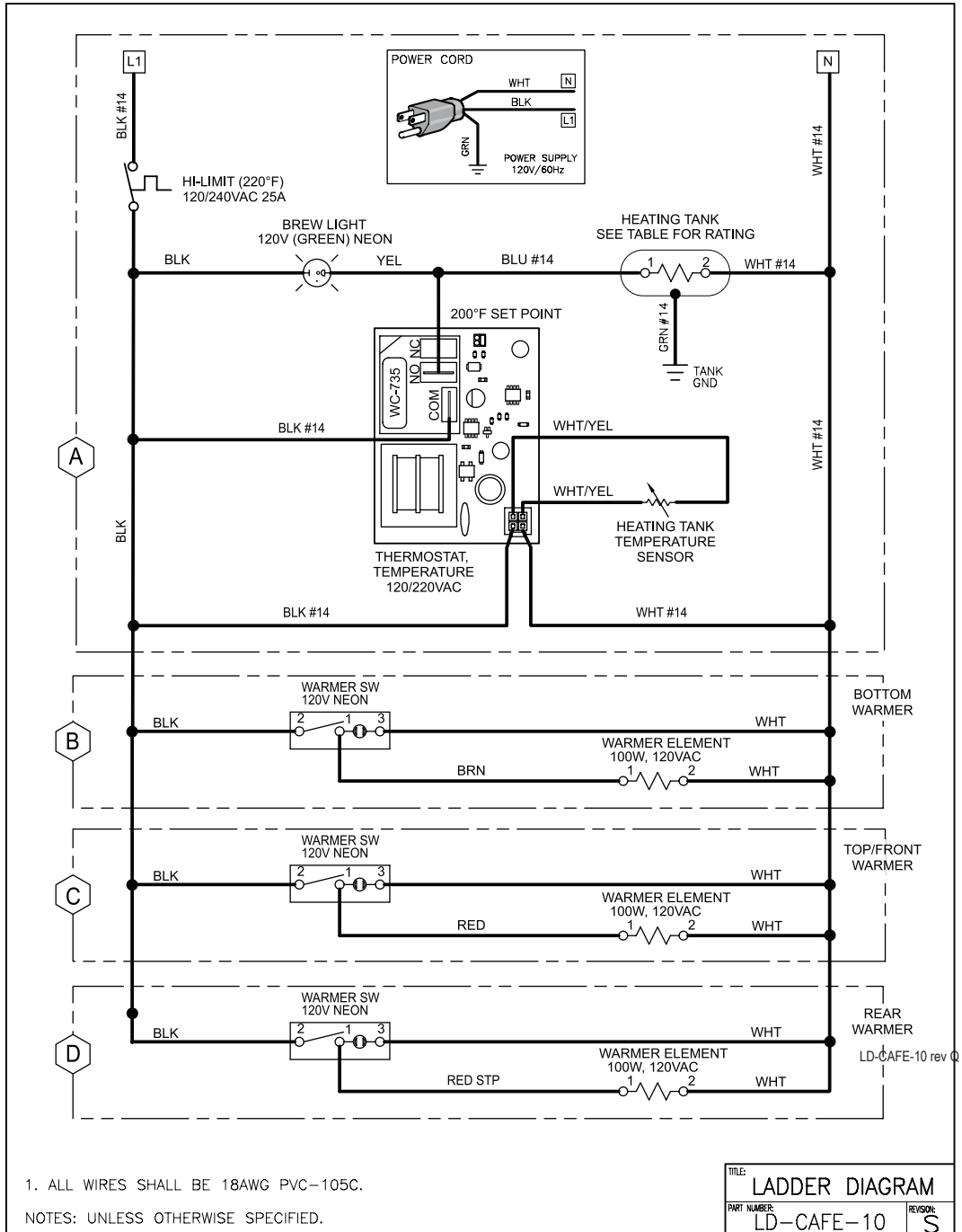

Table 1. MODEL & ELECTRICAL (All 120VAC Units)

MODEL	HEATING ELEMENT	CIRCUIT	VOLTS	WATTS	AMPS	HERTZ	WIRE	PHASE
CAFE0AP10	WC-917	A	120VAC	1450W	12.1A	50/60HZ	2W + G	1-PHASE
CAFE1DB10	WC- 917	A + B	120VAC	1550W	12.9A	50/60HZ	2W + G	1-PHASE
CAFE2DB10	WC- 917	A + B + C	120VAC	1650W	13.8A	50/60HZ	2W + G	1-PHASE
CAFE2DBS10	WC- 917	A + B + C	120VAC	1650W	13.8A	50/60HZ	2W + G	1-PHASE
CAFE3DB10	WC- 917	A + B + C + D	120VAC	1750W	14.6A	50/60HZ	2W + G	1-PHASE
CAFE0PP10	WC- 917	A	120VAC	1450W	12.1A	50/60HZ	2W + G	1-PHASE
CAFE1DB20	WC- 933	A + B	120VAC	1250W	10.4A	50/60HZ	2W + G	1-PHASE
CAFE2DB20	WC- 933	A + B + C	120VAC	1350W	11.3A	50/60HZ	2W + G	1-PHASE
CAFE3DB20	WC- 933	A + B + C + D	120VAC	1450W	12.1A	50/60HZ	2W + G	1-PHASE

# ELECTRICAL LADDER DIAGRAM – 220V

Brewer Model Café 1DB, 2DB, 3DB & AP (All 208-240VAC Units)

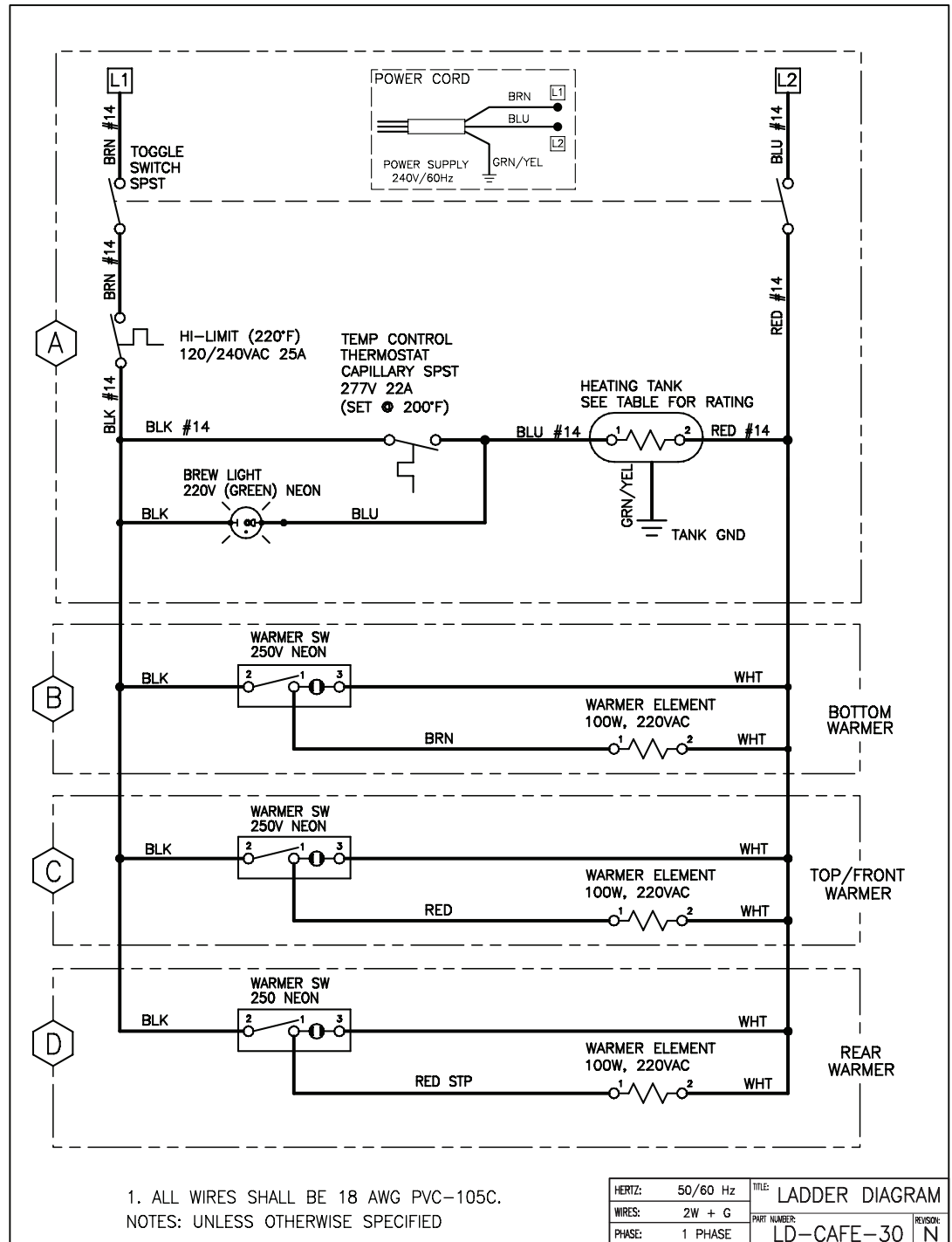

Table 2. MODEL & ELECTRICAL (All 208-240VAC Units) "Export Only"

MODEL AND ELECTRICAL TABLE					
MODEL	HEATING ELEMENT	CIRCUIT	VOLTS	WATTS	AMPS
CAFE0AP30	WC- 906	A	240VAC	2000W	8.3A
CAFE1DB30	WC- 906	A + B	240VAC	2100W	8.8A
CAFE2DB30	WC- 906	A + B + C	240VAC	2200W	9.2A
CAFE3DB30	WC- 906	A + B + C + D	240VAC	2300W	9.6A

---

## Product Warranty Information

The Wilbur Curtis Company certifies that its products are free from defects in material and workmanship under normal use. The following limited warranties and conditions apply:

- 3 Years, Parts and Labor, from Original Date of Purchase on digital control boards.
- 2 Years, Parts, from Original Date of Purchase on all other electrical components, fittings and tubing.
- 1 Year, Labor, from Original Date of Purchase on all electrical components, fittings and tubing.

Additionally, the Wilbur Curtis Company warrants its Grinding Burrs for Forty (40) months from date of purchase or 40,000 pounds of coffee, whichever comes first. Stainless Steel components are warranted for two (2) years from date of purchase against leaking or pitting and replacement parts are warranted for ninety (90) days from date of purchase or for the remainder of the limited warranty period of the equipment in which the component is installed.

All in-warranty service calls must have prior authorization. For Authorization, call the Technical Support Department at 1-800-995-0417. Effective date of this policy is April 1, 2003.

Additional conditions may apply. Go to [www.wilburcurtis.com](http://www.wilburcurtis.com) to view the full product warranty information.

### CONDITIONS & EXCEPTIONS

The warranty covers original equipment at time of purchase only. The Wilbur Curtis Company, Inc., assumes no responsibility for substitute replacement parts installed on Curtis equipment that have not been purchased from the Wilbur Curtis Company, Inc. The Wilbur Curtis Company will not accept any responsibility if the following conditions are not met. The warranty does not cover and is void under the following circumstances:

- 1) **Improper operation of equipment:** *The equipment must be used for its designed and intended purpose and function.*
- 2) **Improper installation of equipment:** *This equipment must be installed by a professional technician and must comply with all local electrical, mechanical and plumbing codes.*
- 3) **Improper voltage:** *Equipment must be installed at the voltage stated on the serial plate supplied with this equipment.*
- 4) **Improper water supply:** *This includes, but is not limited to, excessive or low water pressure, and inadequate or fluctuating water flow rate.*
- 5) **Adjustments and cleaning:** *The resetting of safety thermostats and circuit breakers, programming and temperature adjustments are the responsibility of the equipment owner. The owner is responsible for proper cleaning and regular maintenance of this equipment.*
- 6) **Damaged in transit:** *Equipment damaged in transit is the responsibility of the freight company and a claim should be made with the carrier.*
- 7) **Abuse or neglect (including failure to periodically clean or remove lime accumulations):** *Manufacturer is not responsible for variation in equipment operation due to excessive lime or local water conditions. The equipment must be maintained according to the manufacturer's recommendations.*
- 8) **Replacement of items subject to normal use and wear:** *This shall include, but is not limited to, light bulbs, shear disks, "O" rings, gaskets, silicone tube, canister assemblies, whipper chambers and plates, mixing bowls, agitation assemblies and whipper propellers.*
- 9) **Repairs and/or Replacements** *are subject to our decision that the workmanship or parts were faulty and the defects showed up under normal use. All labor shall be performed during regular working hours. Overtime charges are the responsibility of the owner. Charges incurred by delays, waiting time, or operating restrictions that hinder the service technician's ability to perform service is the responsibility of the owner of the equipment. This includes institutional and correctional facilities. The Wilbur Curtis Company will allow up to 100 miles, round trip, per in-warranty service call.*

**RETURN MERCHANDISE AUTHORIZATION:** All claims under this warranty must be submitted to the Wilbur Curtis Company Technical Support Department prior to performing any repair work or return of this equipment to the factory. All returned equipment must be repackaged properly in the original carton. No units will be accepted if they are damaged in transit due to improper packaging. **NO UNITS OR PARTS WILL BE ACCEPTED WITHOUT A RETURN MERCHANDISE AUTHORIZATION (RMA). RMA NUMBER MUST BE MARKED ON THE CARTON OR SHIPPING LABEL.** All in-warranty service calls must be performed by an authorized service agent. Call the Wilbur Curtis Technical Support Department to find an agent near you.



WILBUR CURTIS CO., INC.

6913 Acco St., Montebello, CA 90640-5403 USA

Phone: 800/421-6150 ♦ Fax: 323-837-2410

♦ Technical Support Phone: 800/995-0417 (M-F 5:30A - 4:00P PST) ♦ E-Mail: [techsupport@wilburcurtis.com](mailto:techsupport@wilburcurtis.com)

♦ Web Site: [www.wilburcurtis.com](http://www.wilburcurtis.com)

FOR THE LATEST SPECIFICATIONS AND INFORMATION GO TO [WWW.WILBURCURTIS.COM](http://WWW.WILBURCURTIS.COM)